

STEREO PLUS 2
SN / SW-CHASSIS
(50 Hz, 4:3 / 16:9)

TV
3 / 1999

Ⓒ **Service manual**
Ⓓ **Service-Manual**
Ⓔ **Serviceanvisning**

Ⓕ **Manuel de service**
Ⓖ **Manuale di servizio**

AKAI

TV 2550-TN
TV 2550-T Multi
TV 2551-TN
TV 2551-TN UK
TV 2551-TN Multi
TV 2850-TN
TV 2850-T Multi
TV 2851-T Multi

TV 2851-T Multi White
TV 2852-T
TV 2852-T Multi
TV 2852-TN UK
TV 2881-T Multi
TV 2881-T Multi UK
TV 3451-T Multi

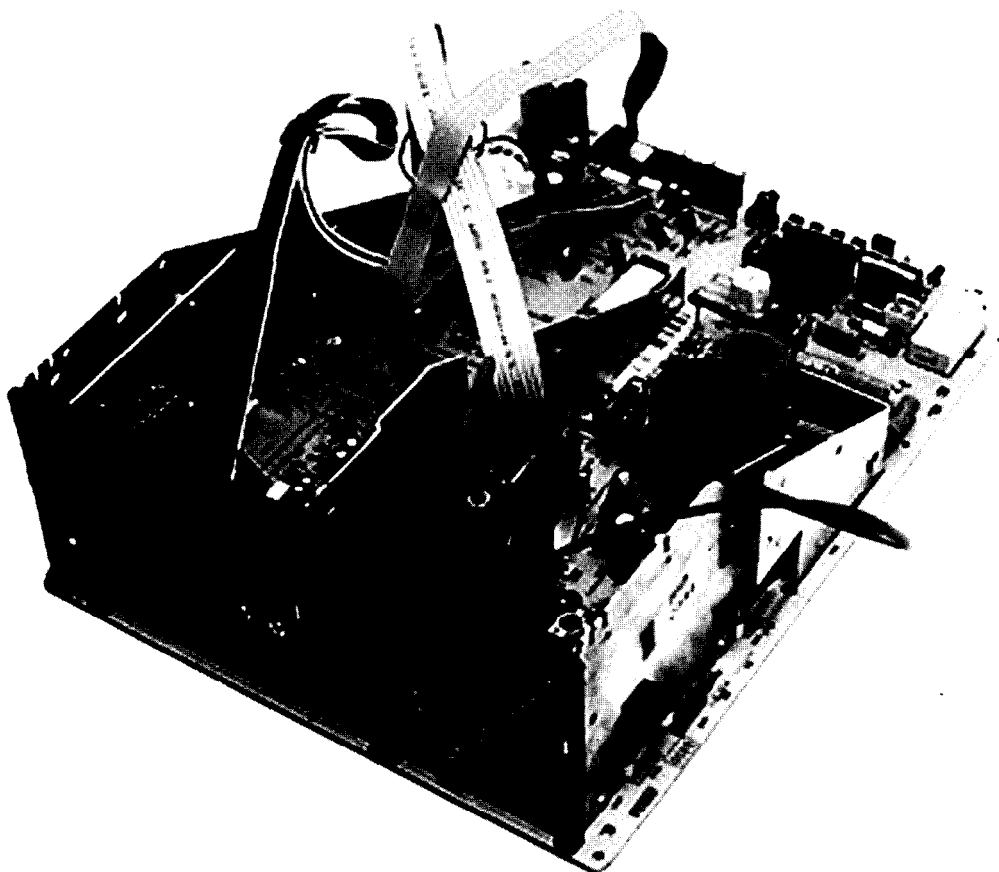

Block diagram, signal routes

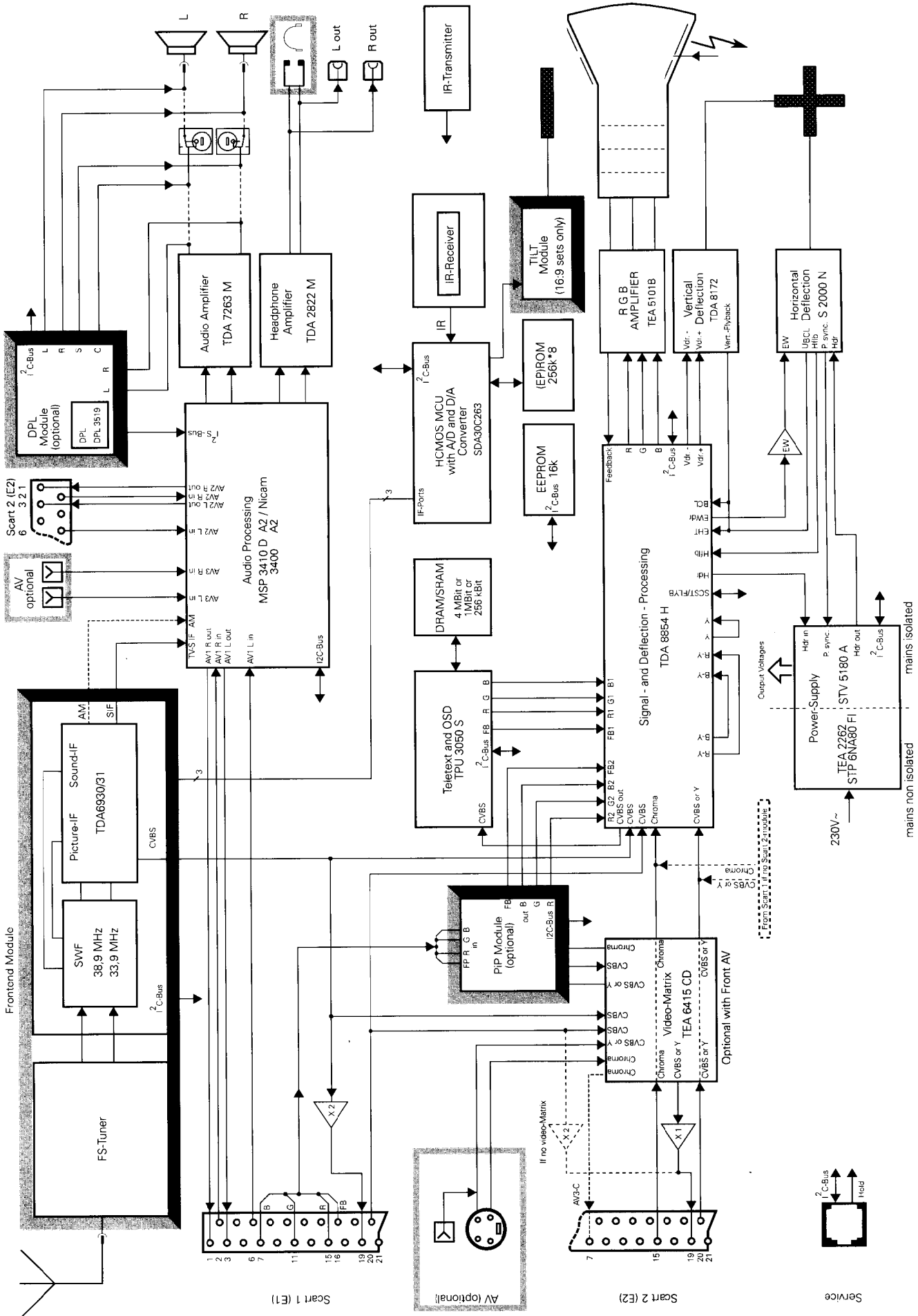

mains non isolated

Output Voltages

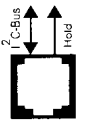

Service

Scart 2 (E2)

Scart 1 (E1)

Block diagram, power supply

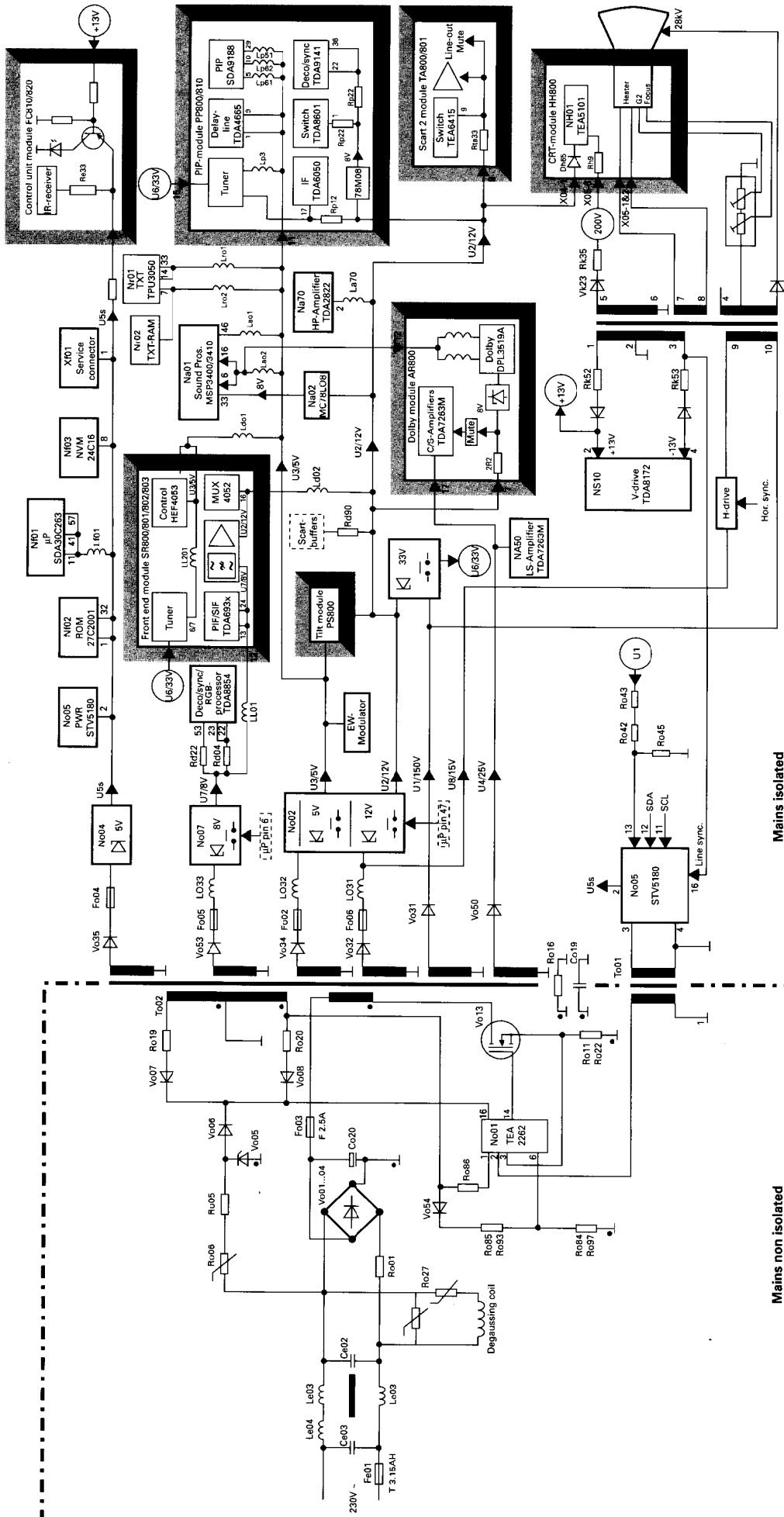

Mains isolated

Mains non isolated

Operating instructions

Changing the menu language

1. Press the yellow button to select the Vision menu.
2. Press the red button to select the Display set-up menu.
3. Change the menu language with cursor buttons.
4. Press the OK button to store the changes.
5. Press the TV button to exit.

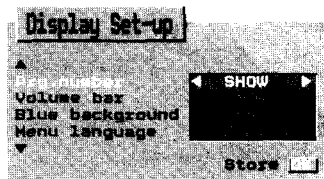

Manual tuning

1. Select the programme number you want to tune.
2. Press the MENU button.
3. Select "Tuning" with the cursor buttons and press the OK button.
4. Select "Manual tuning" and press the OK button.
5. Select "Channel"-line with the cursor buttons and select the channel you want to watch with 3 digits.
6. Press the OK button to store.
7. Press the TV button to exit.

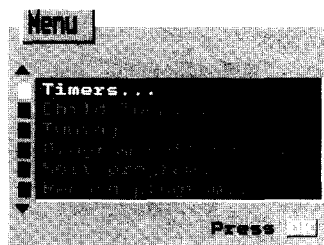

APSi (Automatic Programming System)

1. Press the MENU button.
2. Select "Tuning" with the cursor buttons and press the OK button.
3. Select "Automatic retuning" and press the OK button.
4. To retune the channels, press the red button.

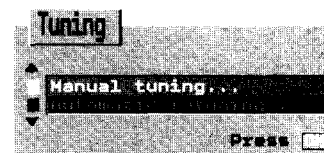

Service adjustments

Service mode activation

Service mode can be enabled whenever the receiver is switched ON or is in stand-by mode.

- 1a) If the receiver is switched ON, press the \blacktriangleleft - (volume minus) button on local control unit and at the same time start entering password: MENU and TV. Release the \blacktriangleleft - button after the MENU button has been pressed.
 - 1b) If the receiver is in stand-by mode, press the \blacktriangleleft - button on local control unit and at the same time start entering password: MENU and TV. Release the \blacktriangleleft - button after the MENU button has been pressed. Switch ON the receiver by pressing the TV button.
2. Activate the service mode by pressing the \mathbf{i} button and exit the service mode by pressing the TV button.
 3. Disable the service mode by switching off the receiver with the mains switch.

Note! Service mode activation stays enabled until the receiver is switched off with the mains button.

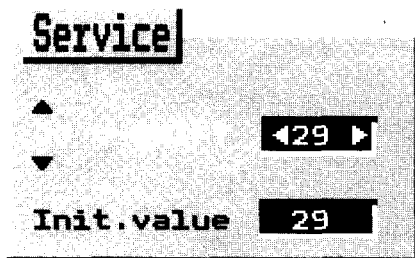

In service mode an adjustment menu is shown on the screen. The adjustment number and name, initializing (bottom) and adjustment (top) values are shown in the menu.

Initialization of NVRAM

Initialization of NVRAM

If the NVRAM is replaced, it must be initialized and configured.

Note! The receiver doesn't start with uninitialized NVRAM, but stays in stand-by mode.

1. Activate the service mode as described in "Service mode activation".
 2. Initialize the NVRAM by entering the key code: BLUE, 2, 5, 4 and OK. Wait approx. 15 seconds and then press the OK button again.
 3. Exit the service mode by pressing the TV-button.
 4. Start the receiver and tune in one or more TV channels with the "manual tuning" method.
- Note! The channel search doesn't work before the reference adjustments (code 12 and 13) have been made, see page 10.*
5. Enter the service mode again and configure the TV set as described in "Configuration and fault diagnosis". (Check that the automatic configuration results in IIC DEV 1&2, AUTO OPT and IF OPT bytes are corresponding to the actual configuration of the TV set.)
 6. Set the manual option bytes (TEXT OPT, HW OPT and SW OPT) to correspond to the actual configuration of the TV set.

7. Make all necessary service adjustments (see section "SERVICE ADJUSTMENTS VIA IIC BUS, page 9)

Note! U1 VALU adjustment must be done first.

8. Disable the service mode by switching off the receiver with the mains switch.

Service adjustments

Configuration and fault diagnosis

The set must be configured after adding or removing any option. By pressing the RED button in service mode, the processor checks the configuration of the TV set and shows the settings on the screen. The configuration can be stored by pressing the OK button.

This feature can also be used in fault diagnosis. If an option bit is not '1' when it should be, the IC (or feature) is either not present or faulty.

Note! IIC DEV 1, IIC DEV 2, AUTO OPT and IF OPT bytes are configured automatically every time the RED-button is pressed.

TEXT OPT, HW OPT and SW OPT bytes must be set manually.

Changing the option bytes

1. Select the configuration mode by pressing the RED button in the service mode.

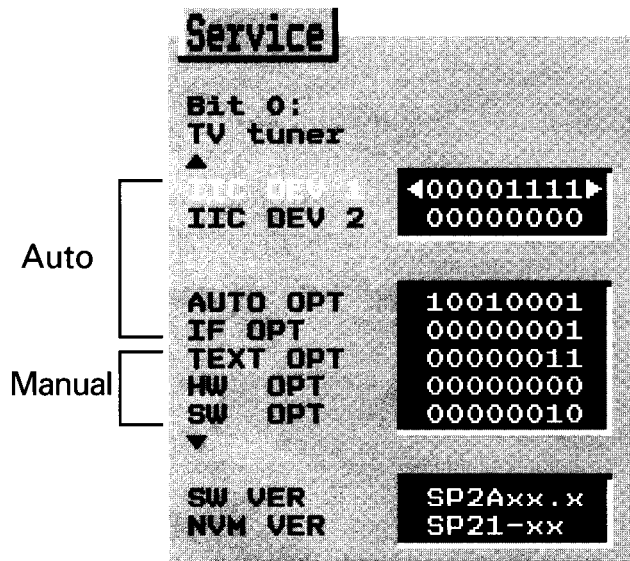

SW VER = μ P software version.

NVM VER = NVRAM software version.

2. Select IIC Device byte 1 - 2 or Option byte 1 - 5 with cursor buttons (up/down). The selected byte is shown highlighted.
The name of a responding bit can be seen by using cursor buttons (left/right).
3. Set / clear the bits with number buttons (0 ... 7).
4. Store the settings by pressing the OK button.
5. Return to the normal service mode by pressing the RED button.

Option byte description

Bit	Description	Setting	'1'	'0'
7 6 5 4 3 2 1 0				
IIC DEV 1 00001111				
0	TV tuner 5002PH5		Yes	No
1	Decoder/sync processor TDA8854		Yes	No
2	Teletext processor TPU3050		Yes	No
3	Sound processor MSP34x0		Yes	No
4	Video matrix switch TEA6415		Yes	No
5	PIP processor		Yes	No
6	PIP tuner		Yes	No
7	3D virtual sound processor		Yes	No
IIC DEV 2 00000000				
5	Power controller STV5180		Yes	No
6	Sound processor MSP3410		Yes	No
7	Reserved for production use		Yes	No
AUTO OPT 10010001				
0	Scart 2		Yes	No
1	16:9 picture tube		Yes	No
3	Text memory 4 Mb DRAM		Yes	No
4	Text memory 1 Mb SRAM		Yes	No
5	Text memory 256 kb SRAM		Yes	No
6	Tilt adjustment		Yes	No
7	NICAM identification enabled		Yes	No
IF OPT 00000001				
0	B/G system in IF		Yes	No
1	I system in IF		Yes	No
2	D/K system in IF		Yes	No
3, 4	L/L' system in IF		Yes	No
5	HEF4094B in IF		Yes	No
TEXT OPT 00000011				
1	FLOF function enabled		Yes	No
7,6,5	Text character set selected			
	000 = West Europe / Czech			
	001 = East Europe			
	010 = West Europe / USA			
	011 = West Europe / Turkish			
	100 = East Europe 2			
HW OPT 00000000				
0	A/V connector installed		Yes	No
1	SVHS input in AV		Yes	No
2	3.58 MHz xtal installed		Yes	No
SW OPT 00000010				
1	Carrier mute enabled		Yes	No
2	Stand-by prevent		Yes	No
3	Autostart enabled (Special use only!)		Yes	No
4	Pal + helper blanking 4:3		Yes	No
5	E1 FB enabled (USER)		Yes	No
7	Hotel TV enabled		Yes	No
SW VER SP2Axx.x				
SW VER = μ P software version				
NVM VER SP21-xx				
NVM VER = NVRAM software version				

Service adjustments via IIC bus

Remote control buttons in service mode

When the receiver is in the service mode you can select normal TV mode by pressing the TV button and return to the service mode by pressing the i button.

Number and cursor buttons are used for service adjustments. The OK button stores the settings.

The yellow button hides/shows the service menu to simplify the picture adjustments.

Making adjustments for different picture formats

Make all adjustments with PAL signal unless otherwise mentioned. Make 4:3 set adjustments with normal 4:3(CLASSIC) picture format and 16:9 set adjustments with wide picture format. Then make the necessary adjustments with other picture formats/signals. The required adjustments are shown in the table below.

Note! Check the configuration of the TV set before making the adjustments and make only the necessary adjustments.

Making a service adjustment

1. Give a two digit code which determines an adjustment (e.g. 00 = vertical shift, see the following tables) with the number buttons. You can also select the adjustment with cursor buttons (up-/down).

Note! Power supply and UG2 adjustments must be done before picture geometry adjustments.

Service

▲
▼
Init.value 29

2. Adjust with the cursor buttons (left/right).

Service

▲
▼
Init.value 29

3. Store the new value by pressing the OK button.

Note!

- To avoid incomplete adjustments store each adjustment in the memory immediately after an adjustment has been made.
- If an adjustment has to be made separately for different picture format/signal, select first the normal mode by pressing the TV button and select then the desired picture format/signal. Return to service mode by pressing the i button.

Picture geometry adjustments

Adjustment	Code	OSD name	4:3 sets				16:9 sets				RGB	60 Hz signal	Note!
			CLASSIC (4:3)	MOVIE (4:3)	MOVIE LIFTED (4:3)	WIDE (4:3)	CLASSIC (16:9)	IDEAL (16:9)	FULL (16:9)	FULL LIFTED (16:9)			
Vertical off-centre shift	00	V-SHIFT	X								X		Center line
Vertical amplitude	01	V-AMPL.	X								X	X	Adjust upper side
Vertical slope	02	V SLOPE	X								X		Adjust lower part
Vertical S-correction	03	S-CORR.	X				X				X		
Vertical zoom	04	VER ZOOM	(X)	X		X	X	X			(X)		Recommended to use init value first!
Vertical scrolling	05	V SCROLL	(X)			X				X	(X)		Recommended to use init value first!
Width	06	WIDTH	X	X			X				X	X	
Horizontal shift deflection	07	H-SHIFT	X								X	X	
Parabola	08	PARABOLA	X								X		
Corner	09	CORNER	X								X		
Trapezium	10	TRAPEZ	X								X		

Service adjustments

O Power supply block

Supply voltage and protection circuit

1. Set the brightness and the contrast to the normal level. Connect a universal voltmeter to the cathode of Vo31.
2. Adjust the U1 voltage with U1 VALU in the service mode. (The voltage depends on the picture tube type, refer to the section "Variable components").
3. Check the over-current protection after making any service operations in the primary circuit of the power supply. Switch the set to stand-by mode. Short circuit the cathode of Vo50 to the ground and keep the short circuit connected. When the over-current protection works correctly, the power supply stops permanently. Switch off the receiver by pressing the mains button. Remove the short circuit and then switch on the receiver by pressing the mains button.

AFC adjustments (code 12 and 13)

- 1) The right value is found when while changing the value, the AFC display changes from 0 to 1.
- 2) Adjust with a channel sent with L'-standard. Needed only in multinorm TV sets.

*Note! Use the right channel frequency.
Tune the channel with "manual tuning method"
(see page 7).*

K Horizontal deflection block

Focusing

Set the brightness and the contrast to the normal level. Use the crosshatch pattern and adjust the picture for optimum resolution.

(Screen grid voltage) Ug2 voltage

1. Set the brightness and the colour saturation to the normal level and the contrast to minimum.
2. At the end of the vertical blanking, there is a black current measurement pulse (clamp pulse) at pin 9, 12 and 15 of NH01. Use an oscilloscope and find the output stage with the highest cut-off (i.e. the highest voltage during the black current measurement pulse).
3. Adjust the voltage of the upper clamp pulse to +150 V with Ug2 (see figure).

Note! Adjust the voltage with a clamp pulse.

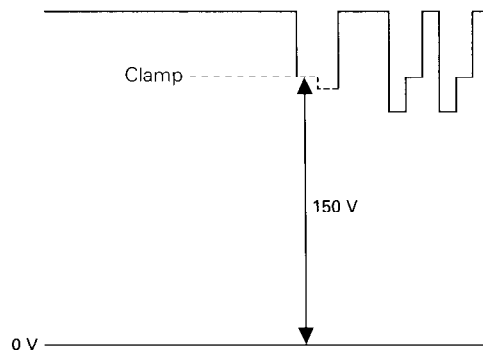

Other adjustments

Adjustment	Code	OSD name	RF OTHER	RF SECAM L	SCART	Note!
Luma delay	11	Y-DELAY	X	X	X	
IF 33.9 reference voltage for AFC	12	REF 339				1), 2)
IF 38.9 reference voltage for AFC	13	REF 389				1)
STV5180 DAC value for U1 control	14	U1 VALU				Must be done before other adjustments!
Red gain	15	R GAIN				
Green gain	16	G GAIN				
Blue gain	17	B GAIN				

FC810 Control unit module

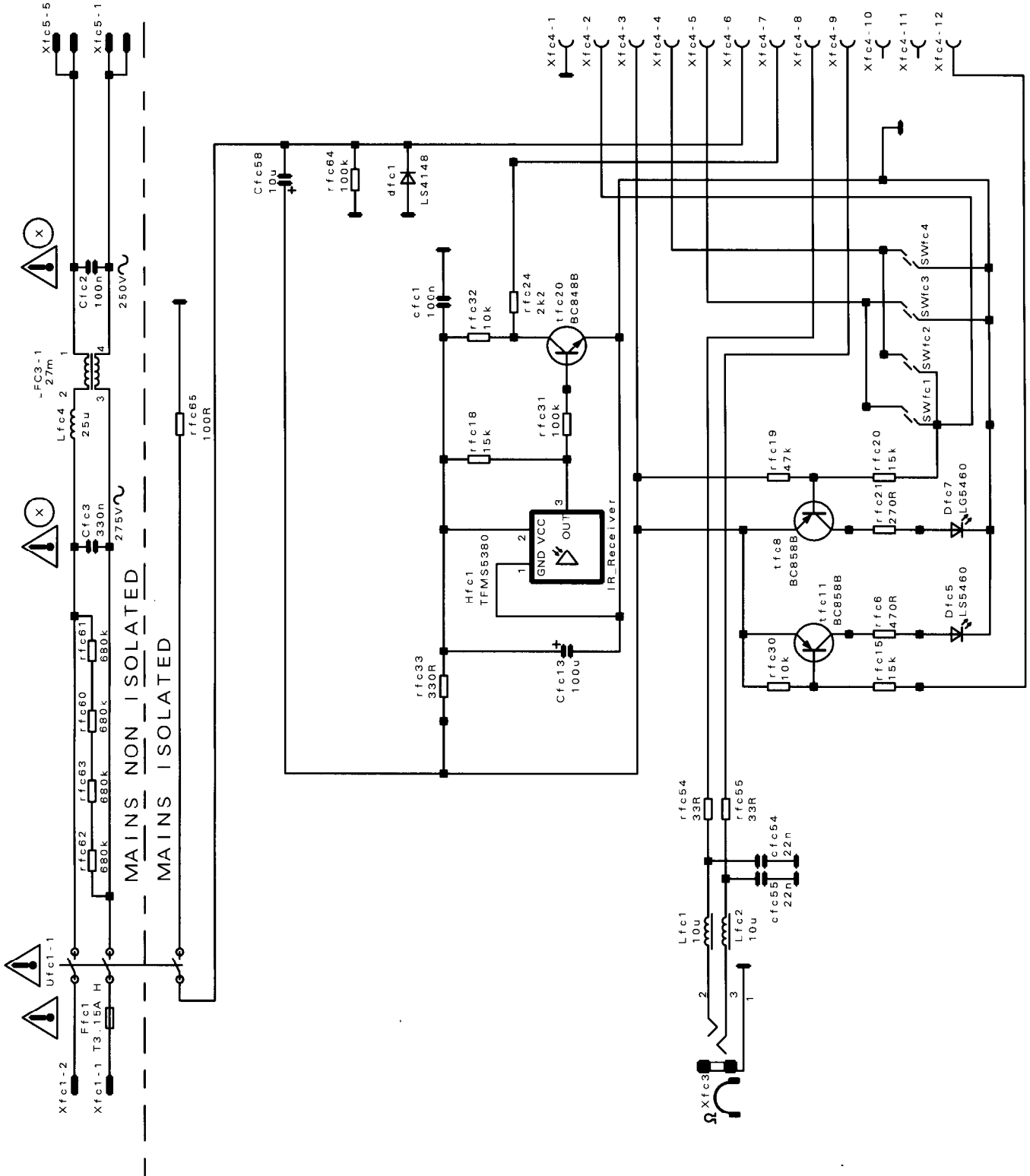

FC820 Control unit module

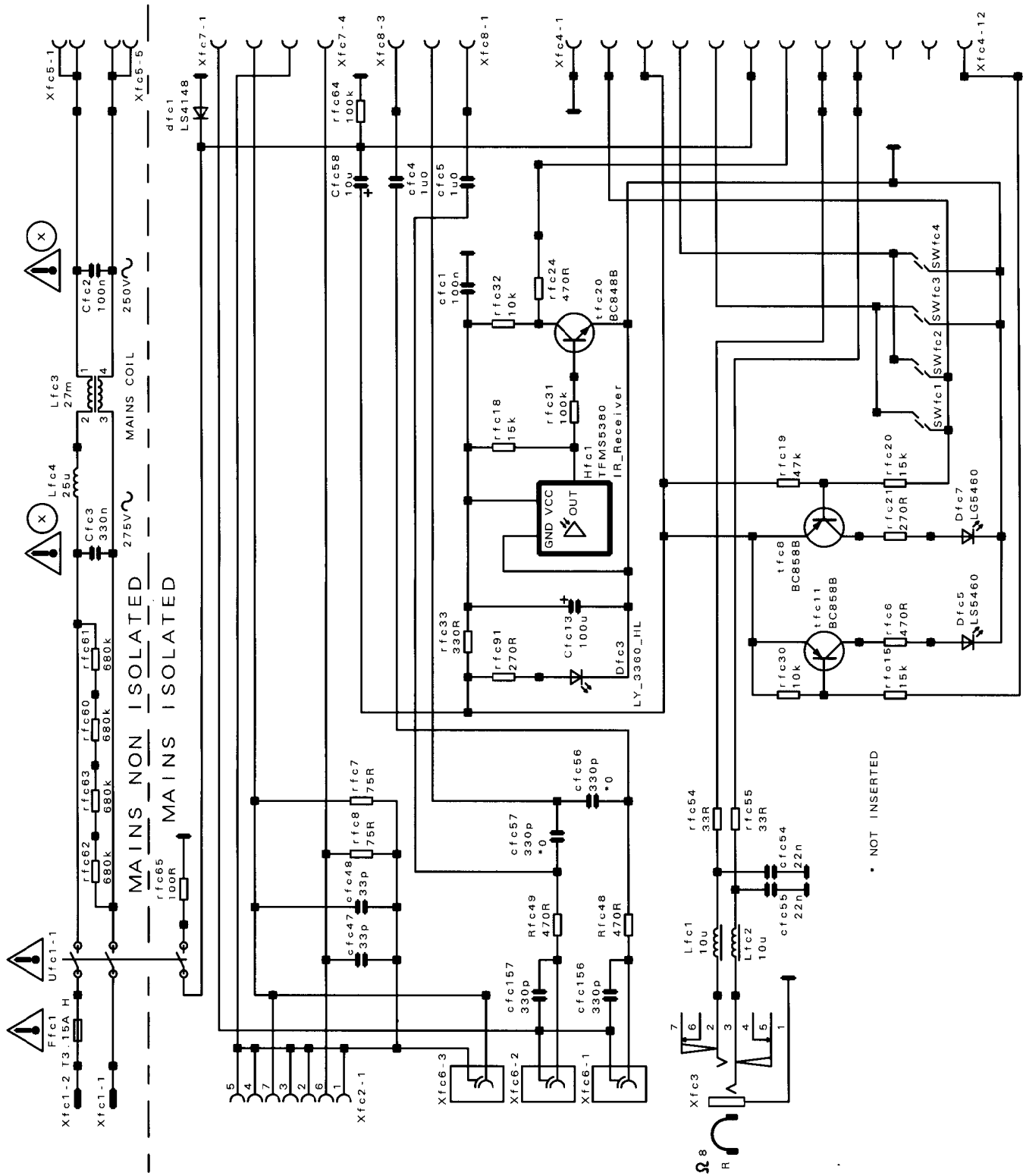

SR801 Frontend module (Multinorm)

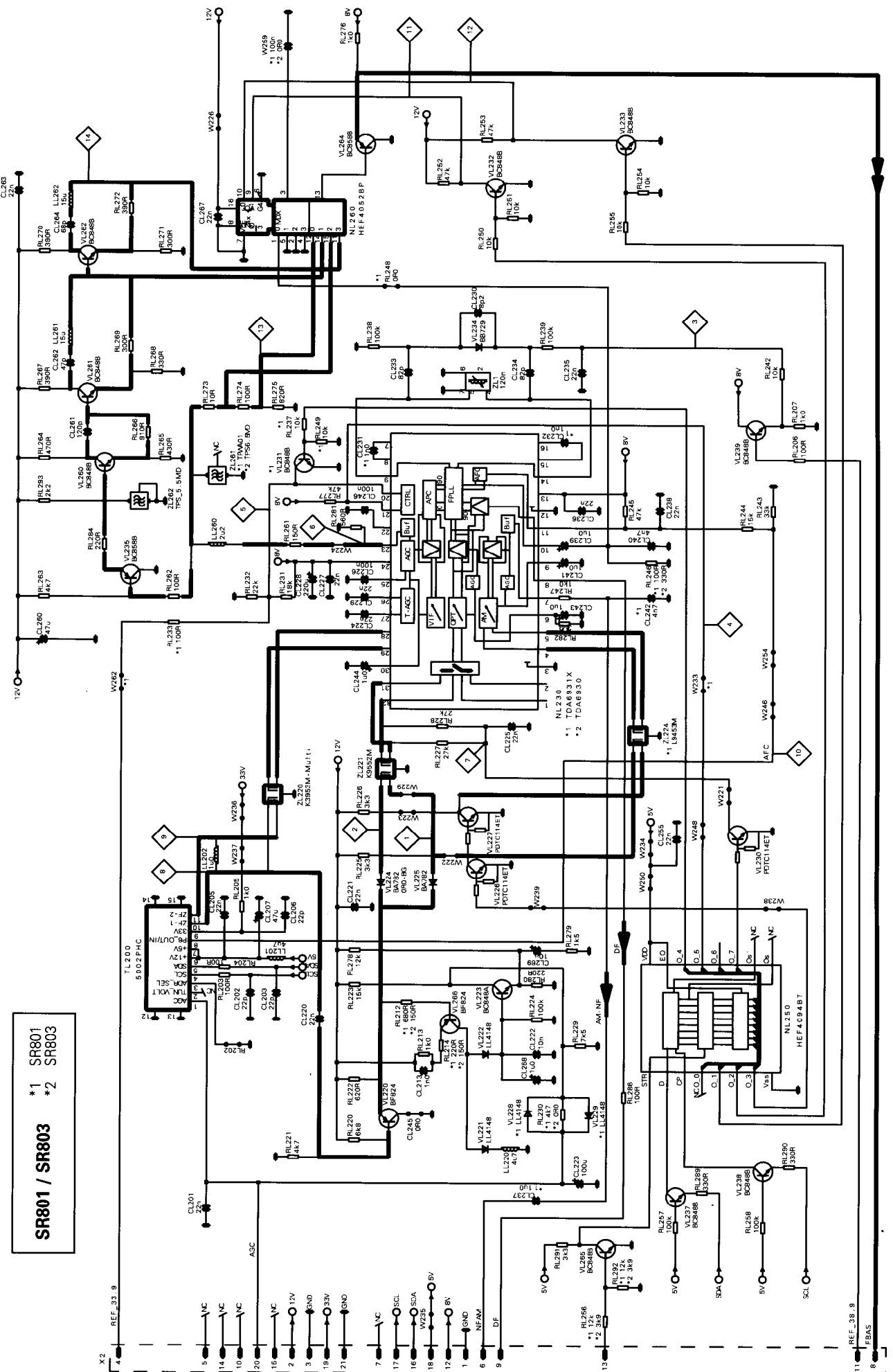

SR801 / SR803
*1 SR801
*2 SR803

REF_38.8
FBAS

TA800 AV / Scart 2 module

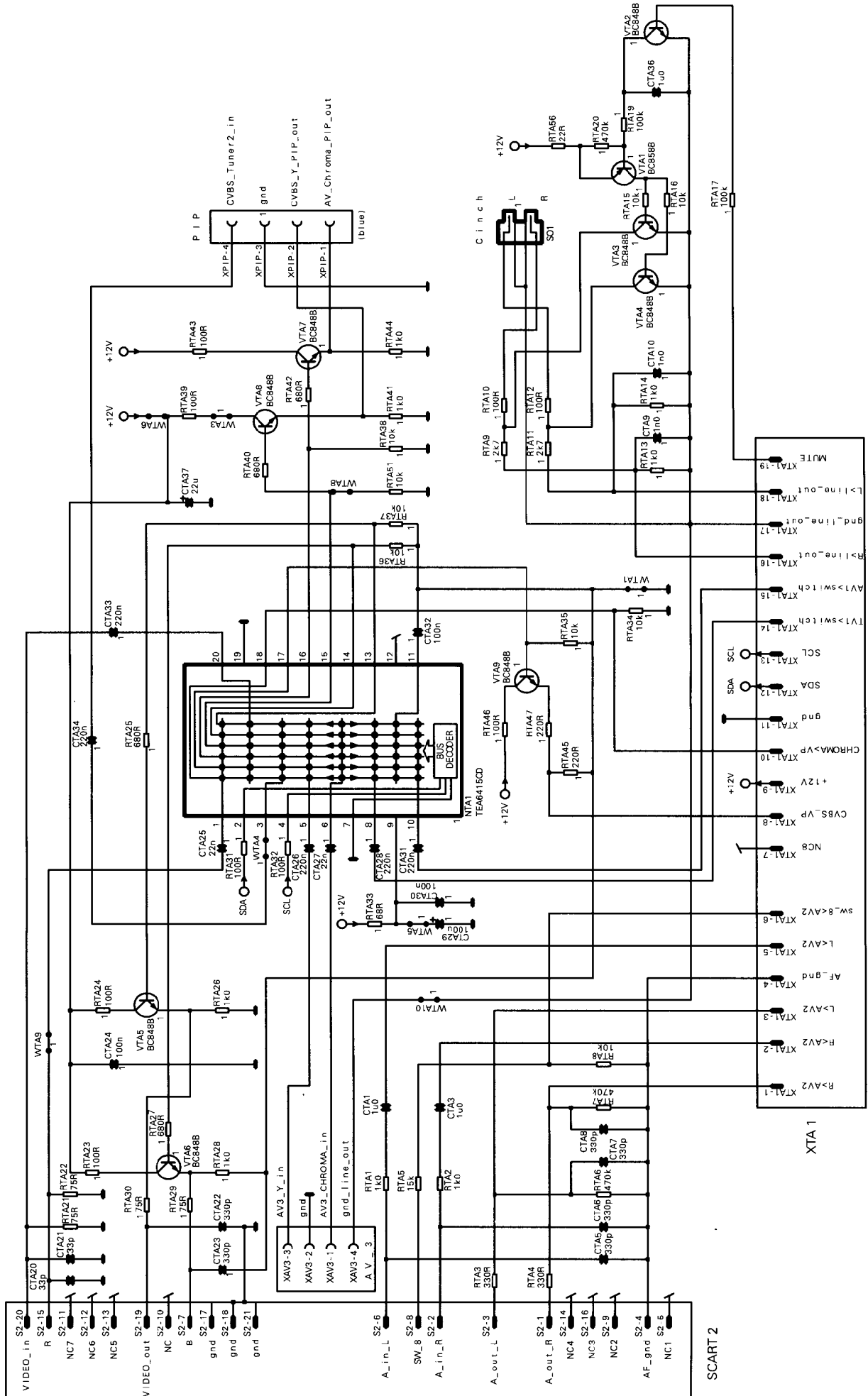

SCART 2

XTA 1

TA801 Scart 2 module

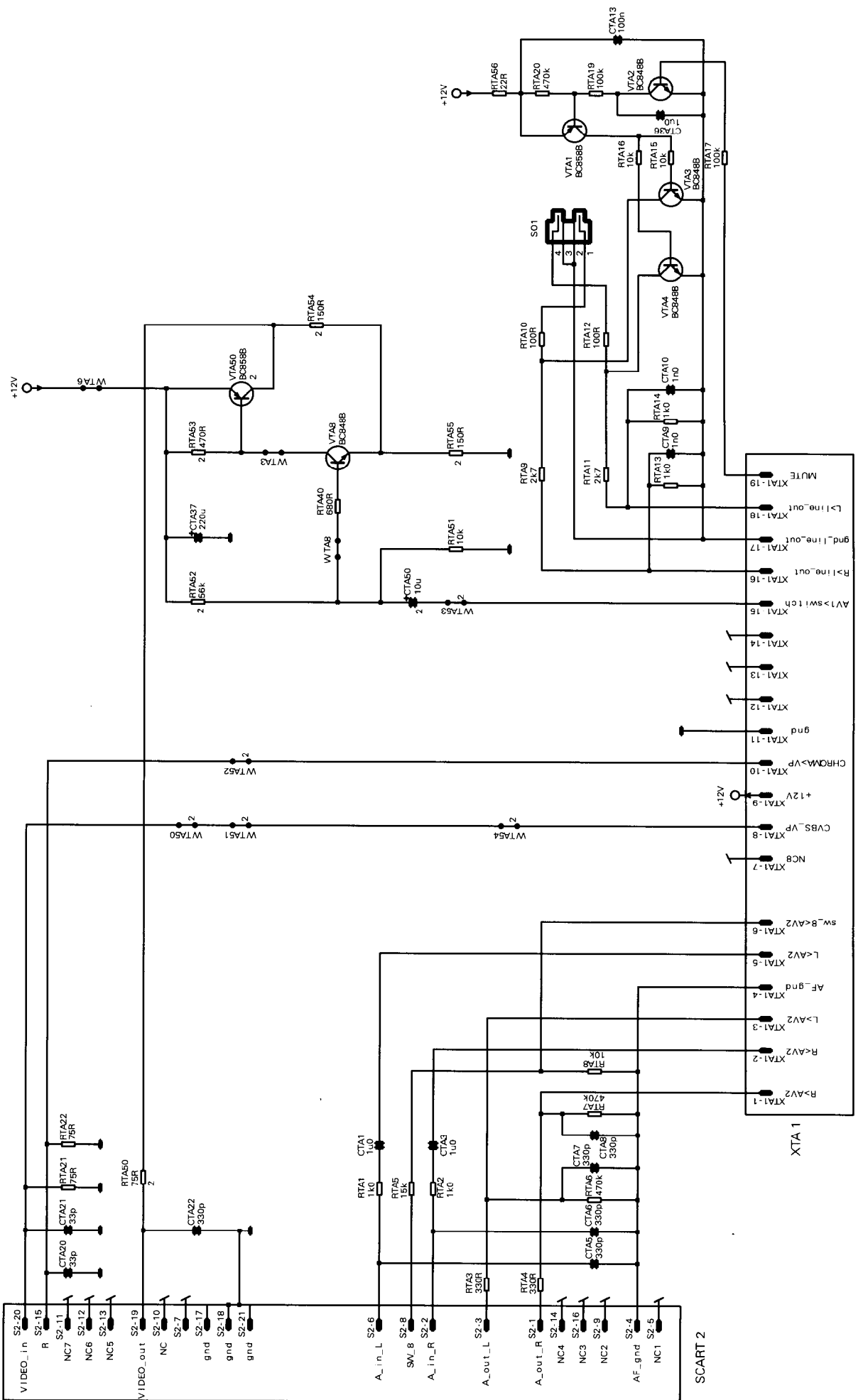

HH800/HH810

CRT module

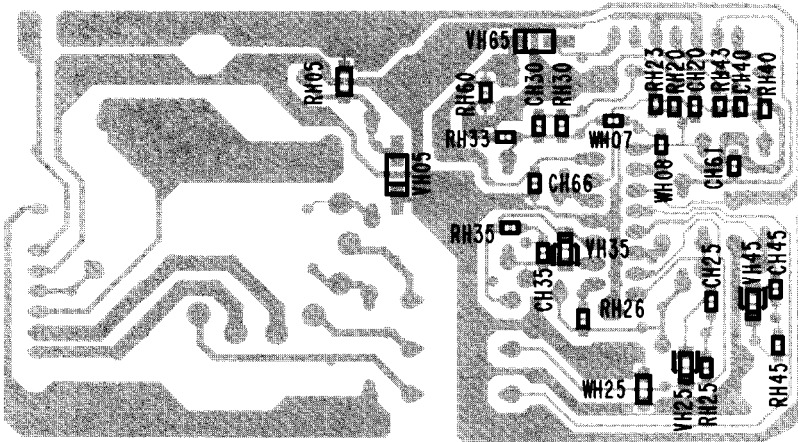
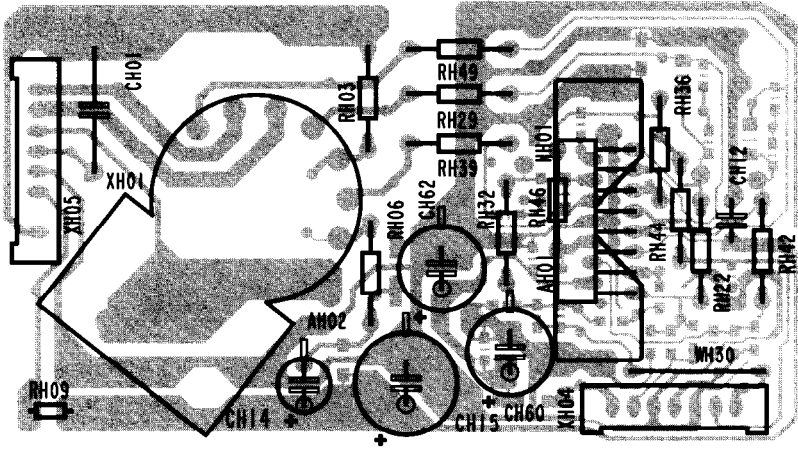

PS800

Picture tilt module

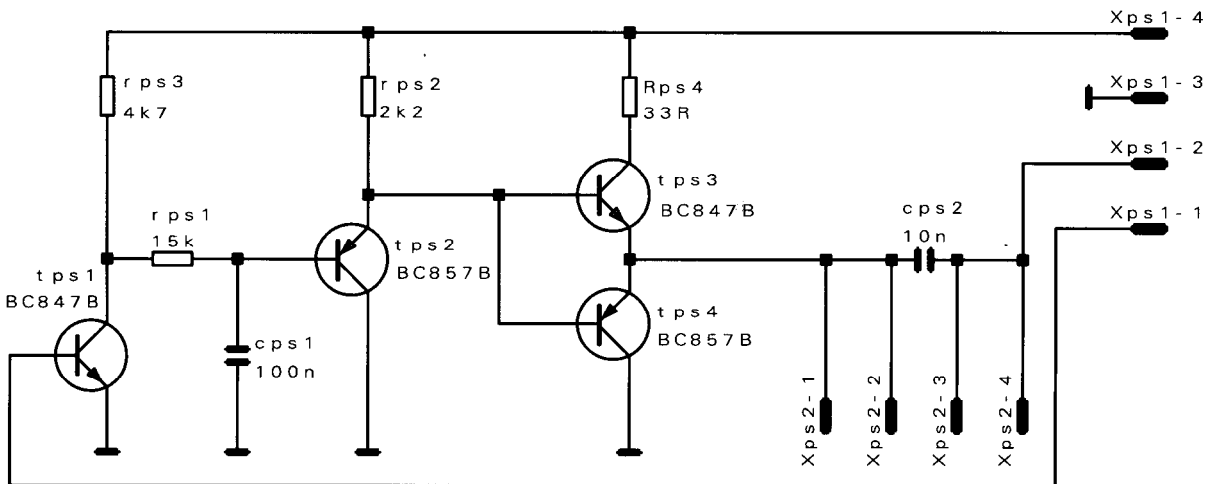
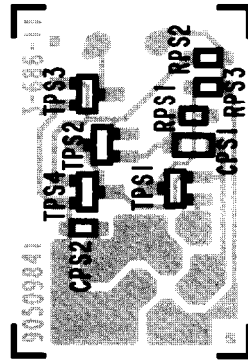
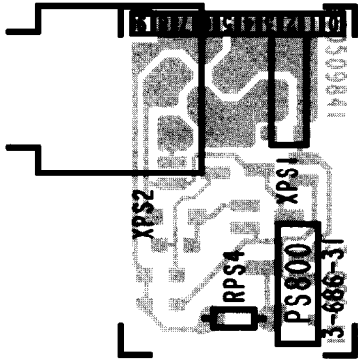

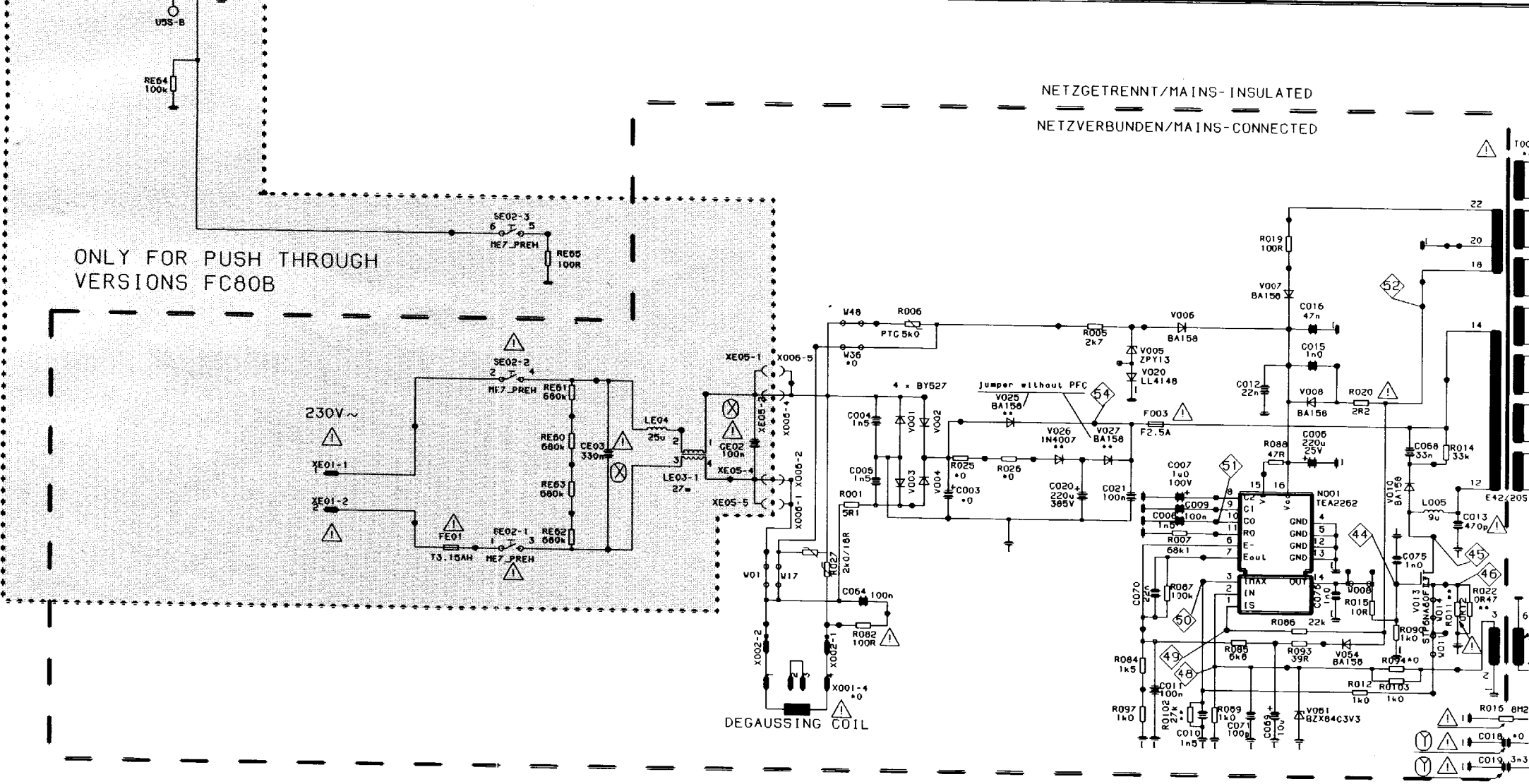
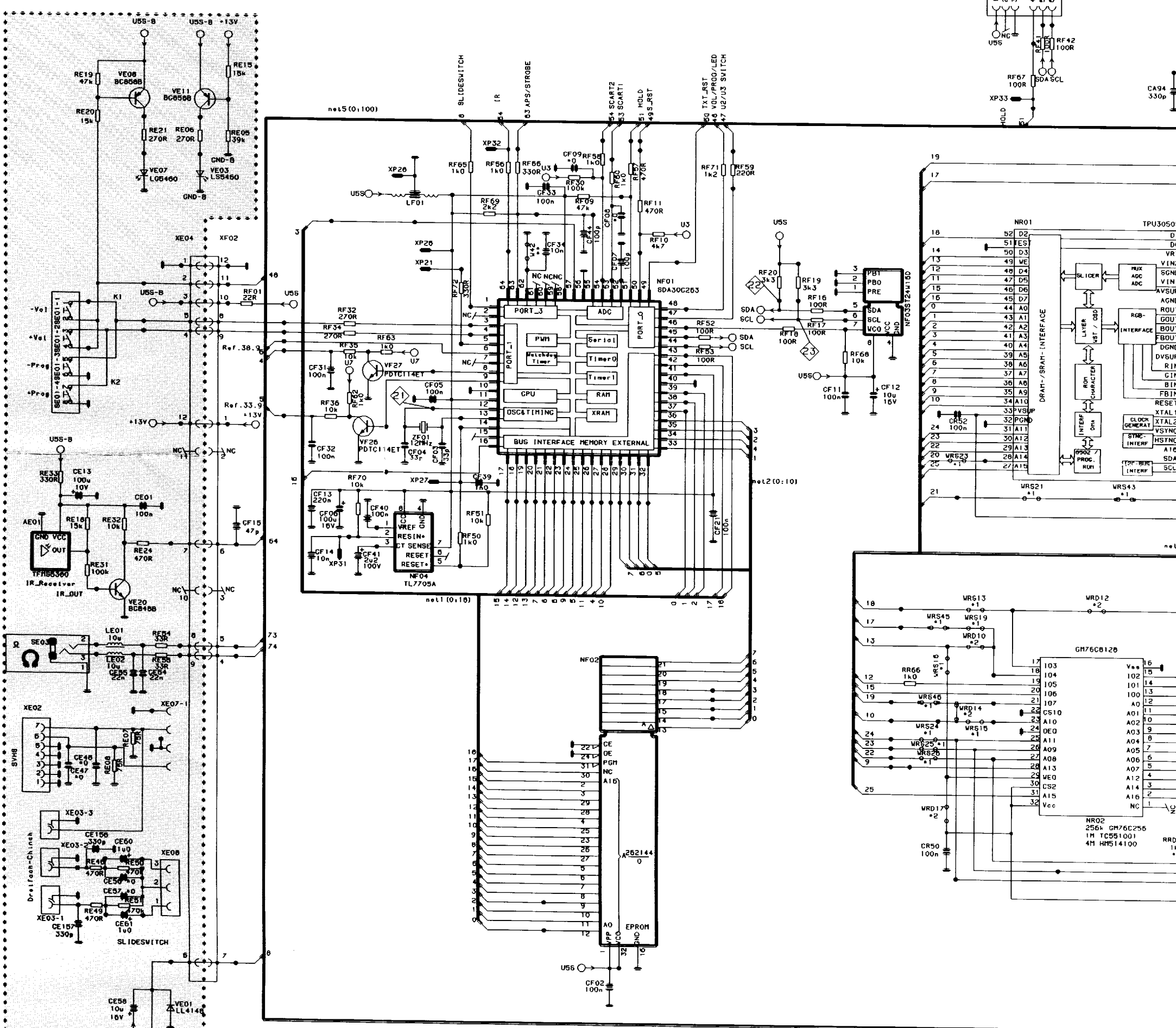

NETZGETRENNT/MAINS-INSULATED
 NETZVERBUNDEN/MAINS-CONNECTED

ONLY FOR PUSH THROUGH
 VERSIONS FC80B

DEGAUSSING COIL

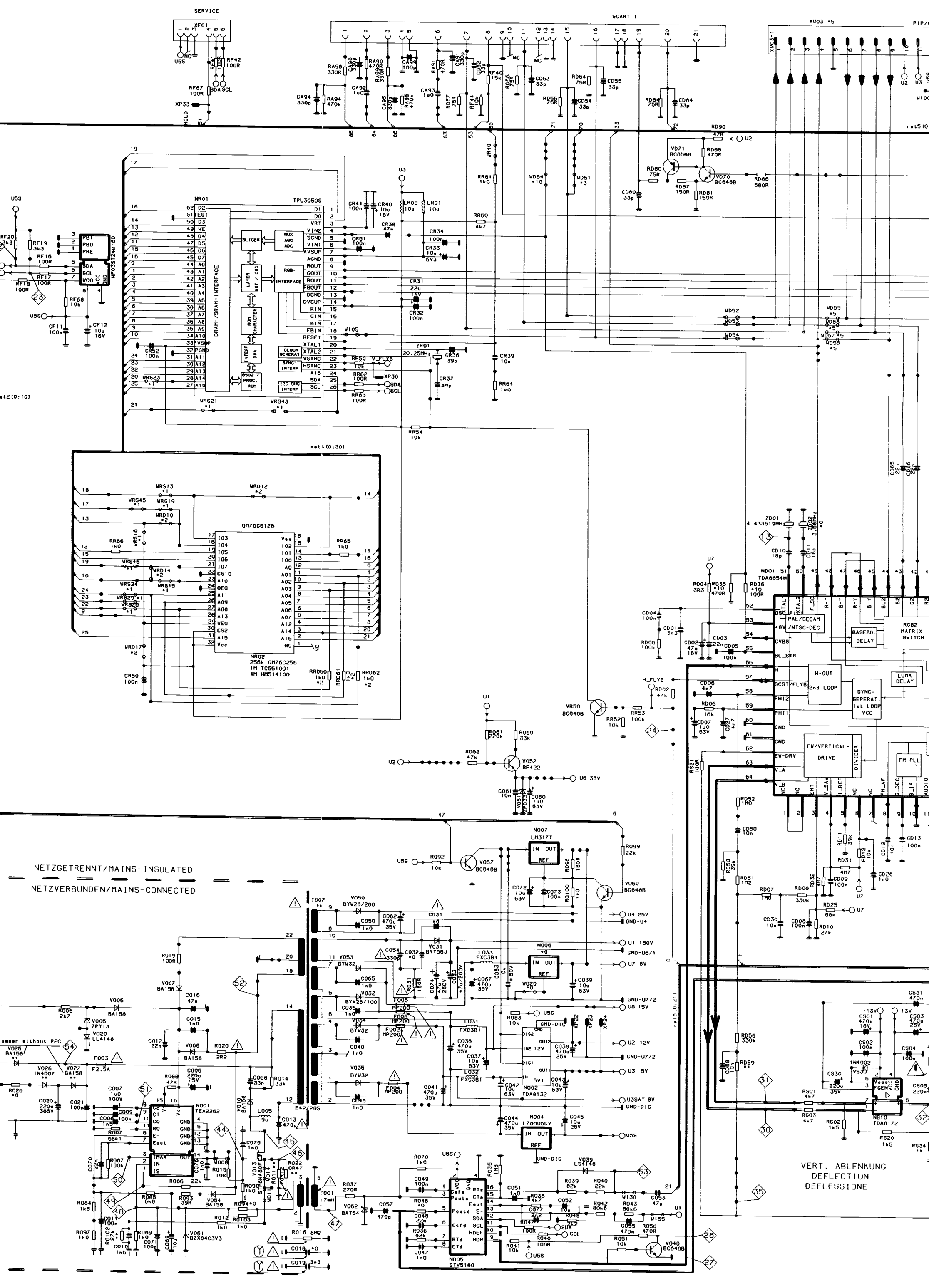

SERVICE

5GART I

XV03 +5

PIP

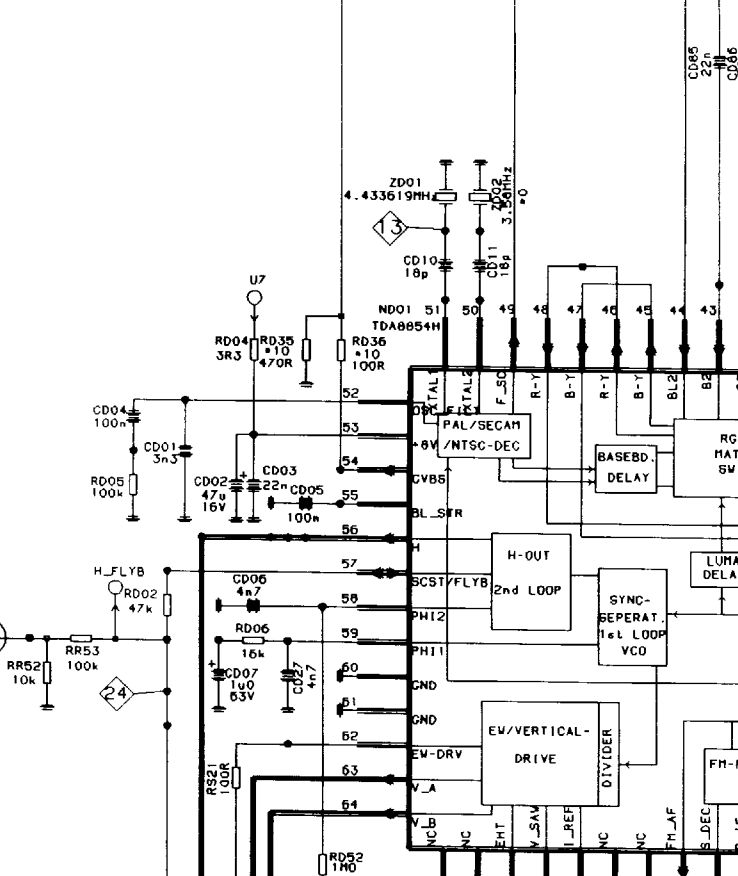
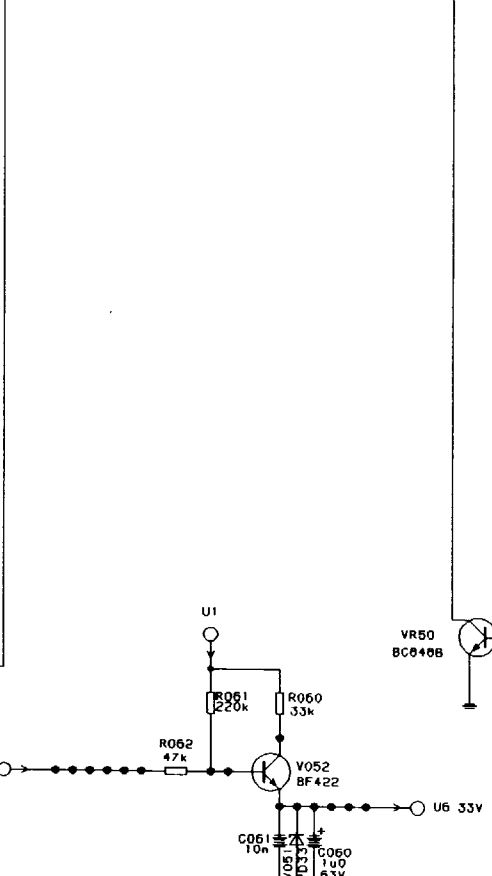
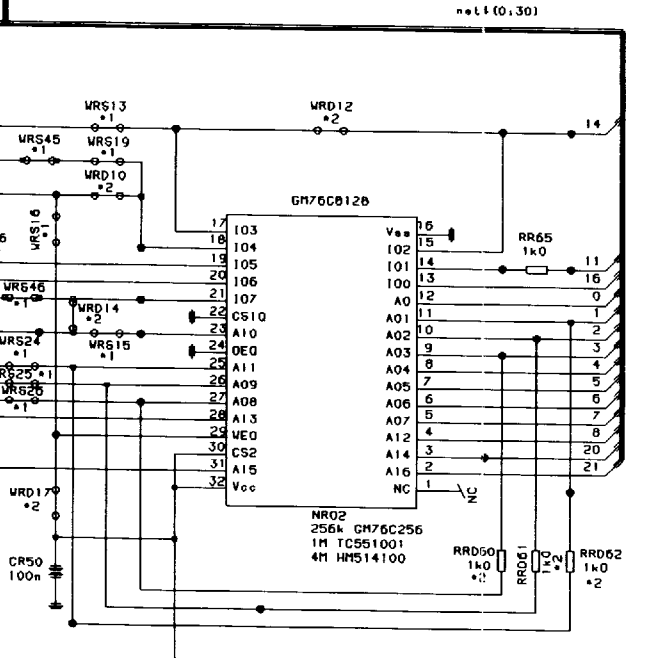
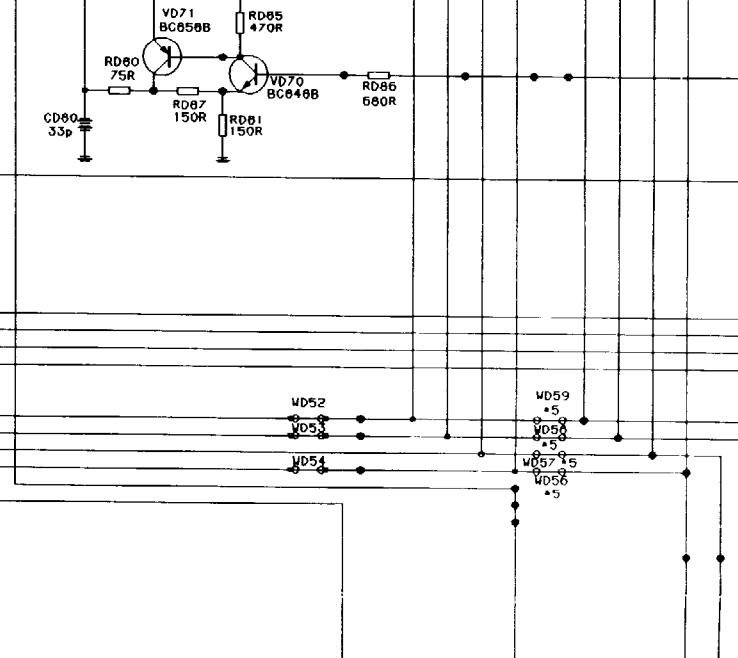
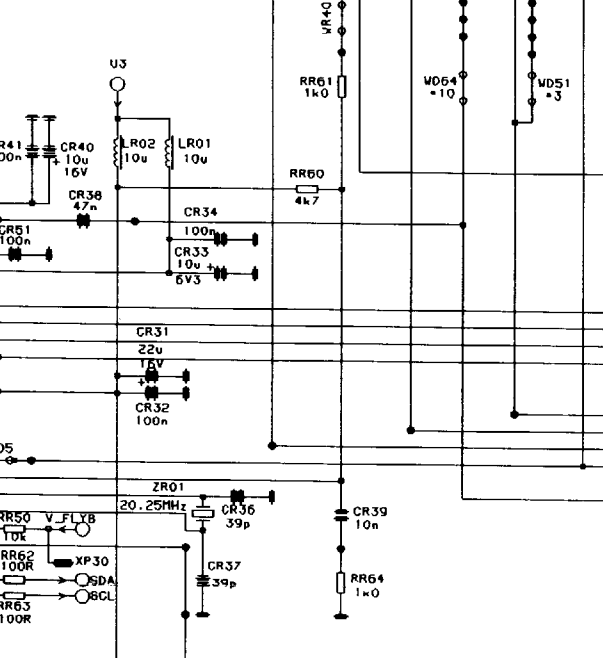
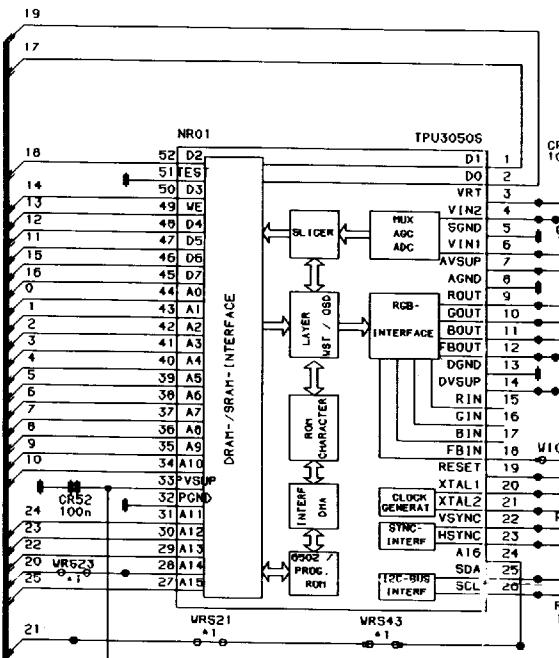

NETZGETRENNT/MAINS-INSULATED
NETZVERBUNDEN/MAINS-CONNECTED

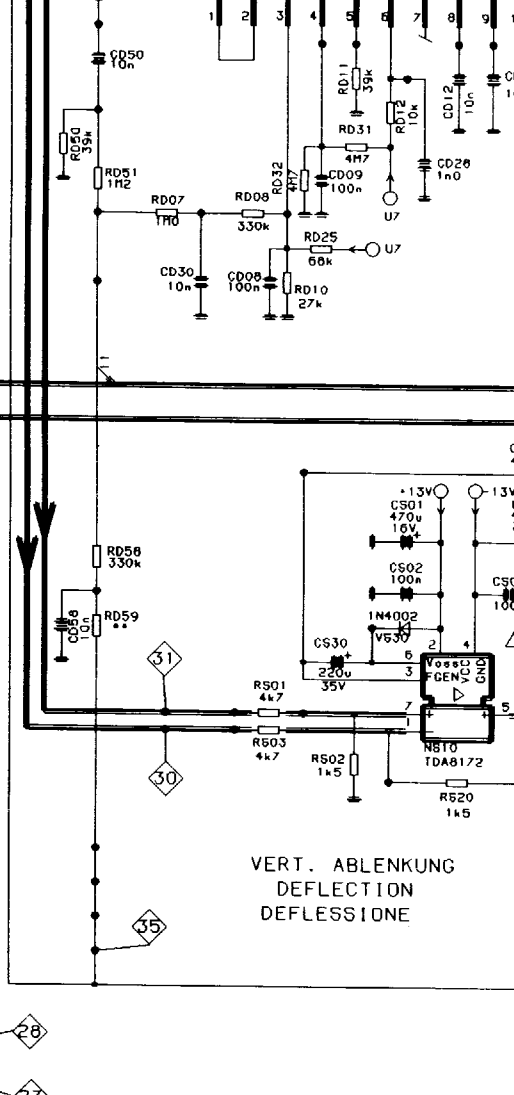
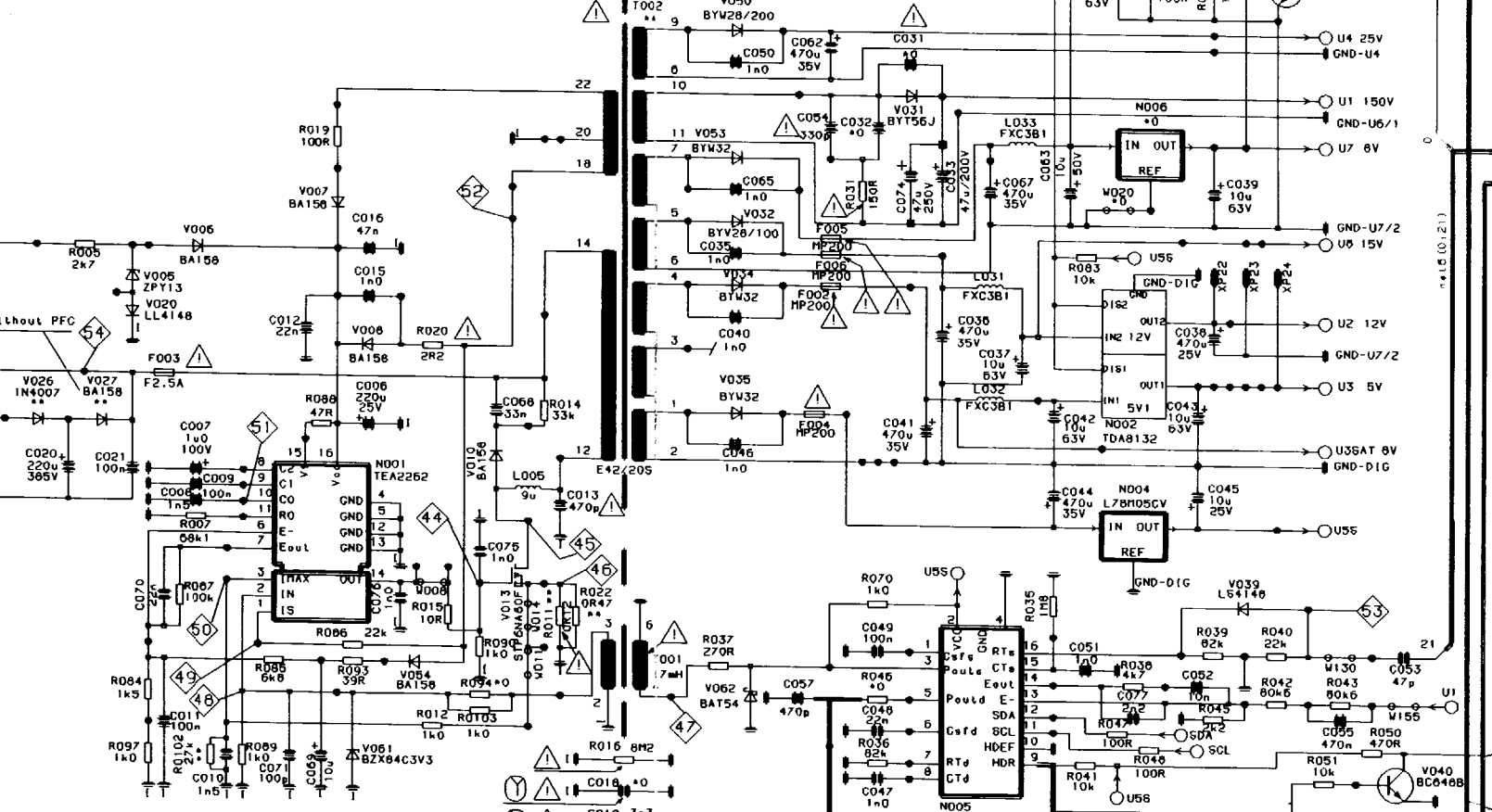

VERT. ABLENKUNG
DEFLECTION
DEFLECTION

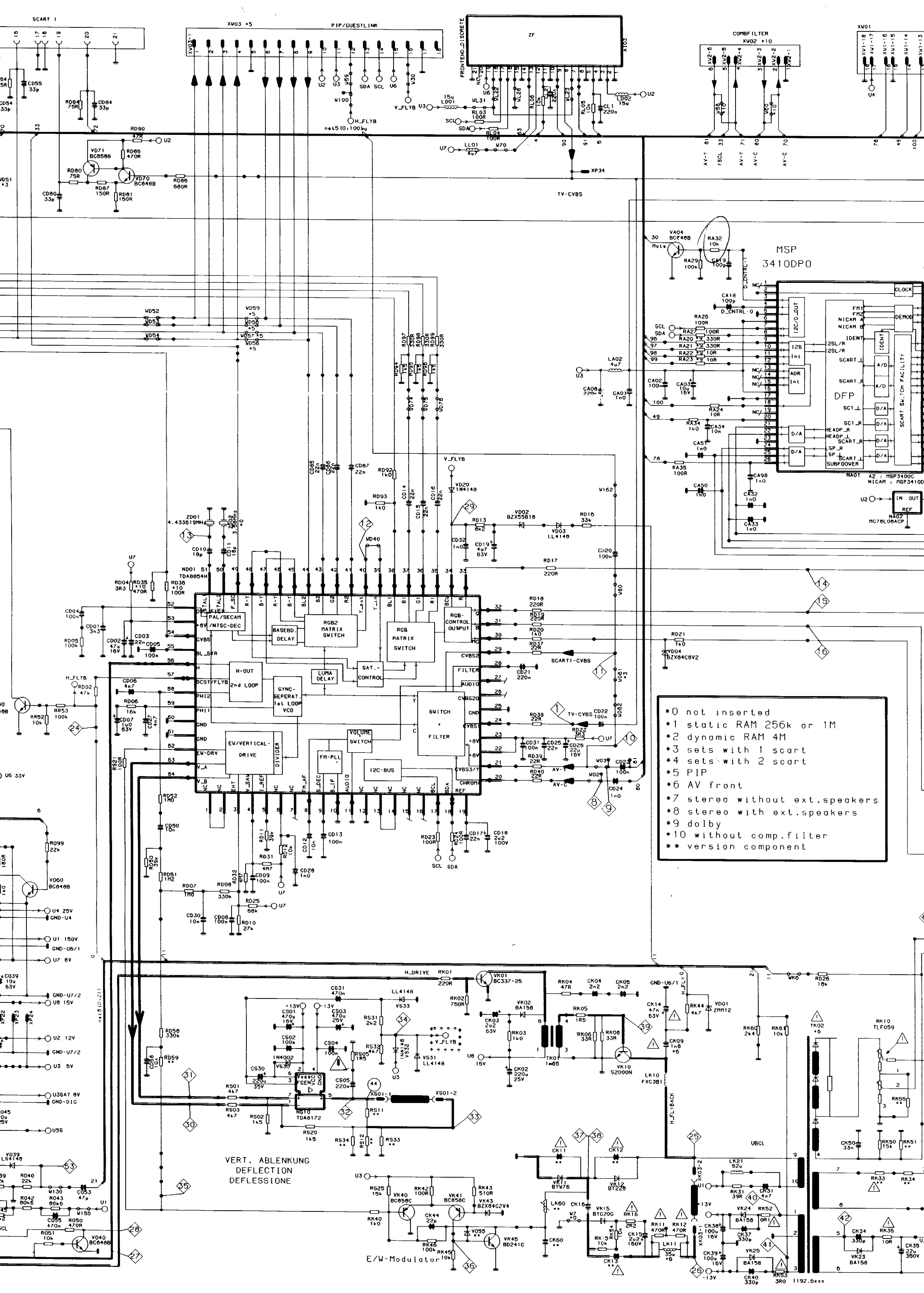

- *0 not inserted
- *1 static RAM 256k or 1M
- *2 dynamic RAM 4M
- *3 sets with 1 scart
- *4 sets with 2 scart
- *5 PIP
- *6 AV front
- *7 stereo without ext. speakers
- *8 stereo with ext. speakers
- *9 dolby
- *10 without comp. filter
- * version component

VERT. ABLENKUNG
DEFLECTION
DEFLESSIONE

E/W-Modulator

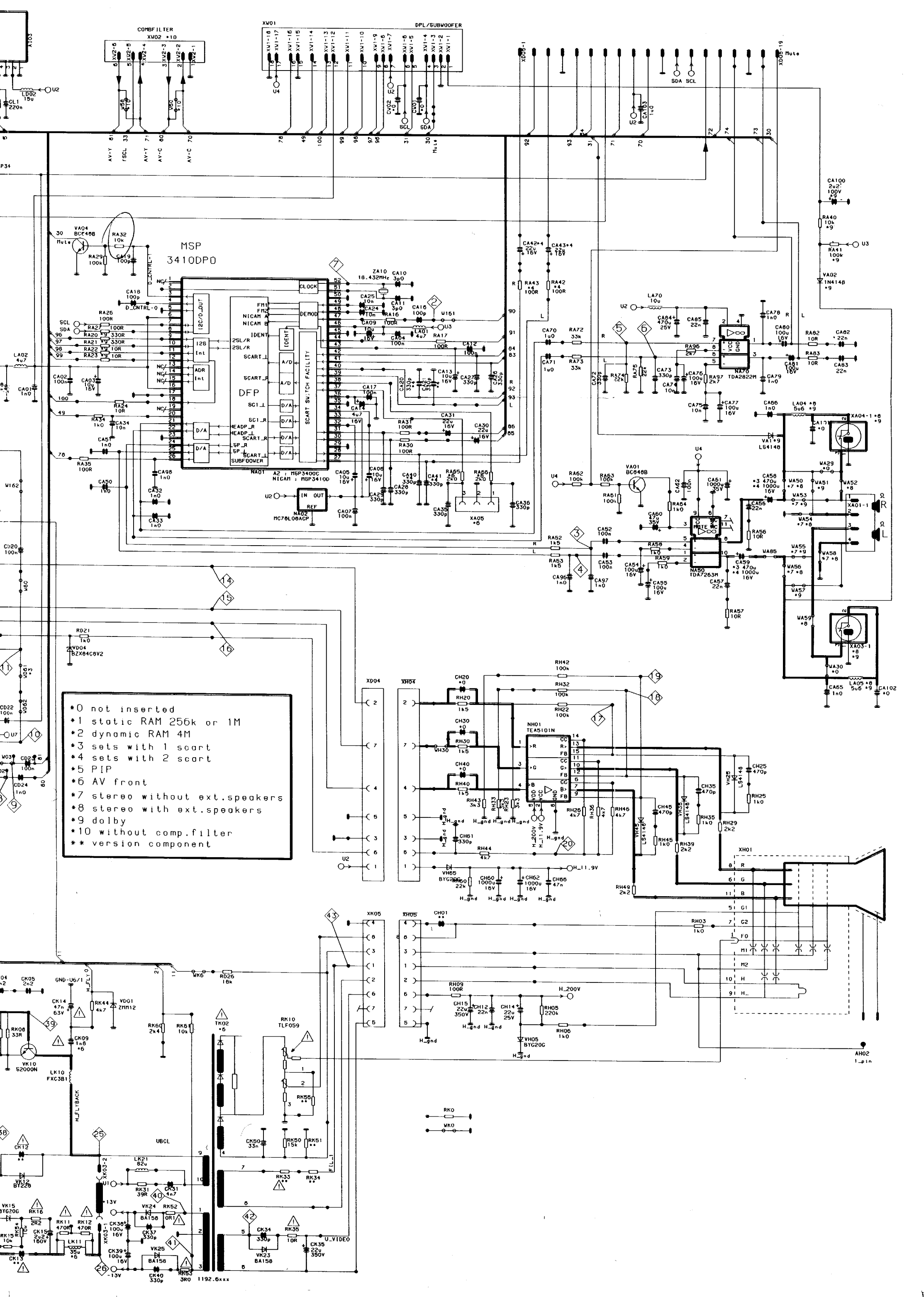

*0 not inserted
 *1 static RAM 256k or 1M
 *2 dynamic RAM 4M
 *3 sets with 1 scart
 *4 sets with 2 scart
 *5 PIP
 *6 AV front
 *7 stereo without ext. speakers
 *8 stereo with ext. speakers
 *9 dolby
 *10 without comp. filter
 ** version component

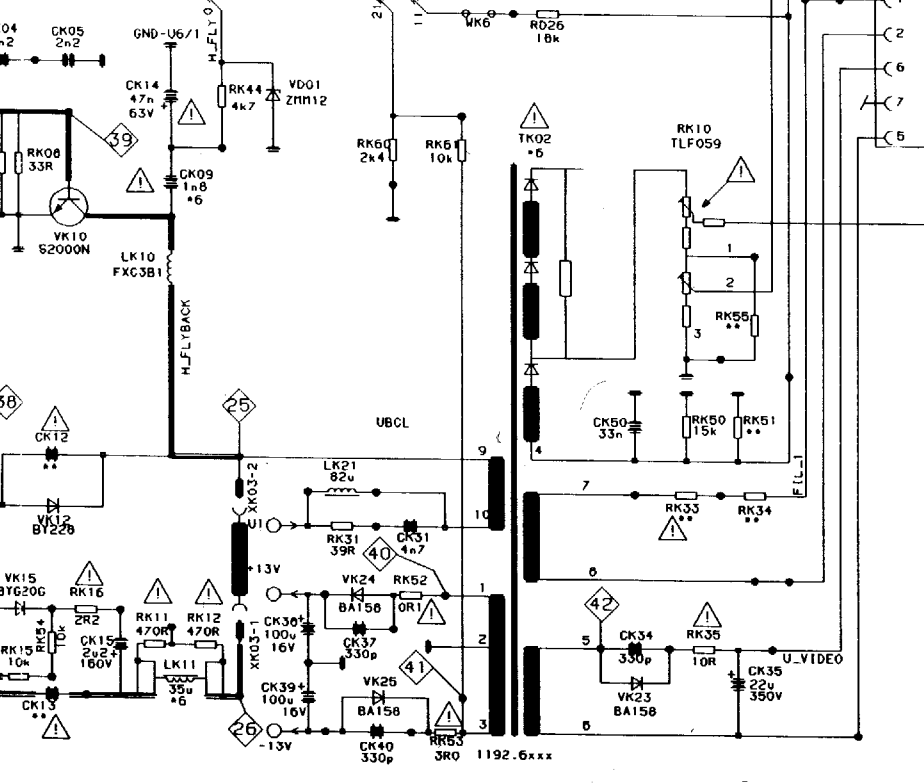
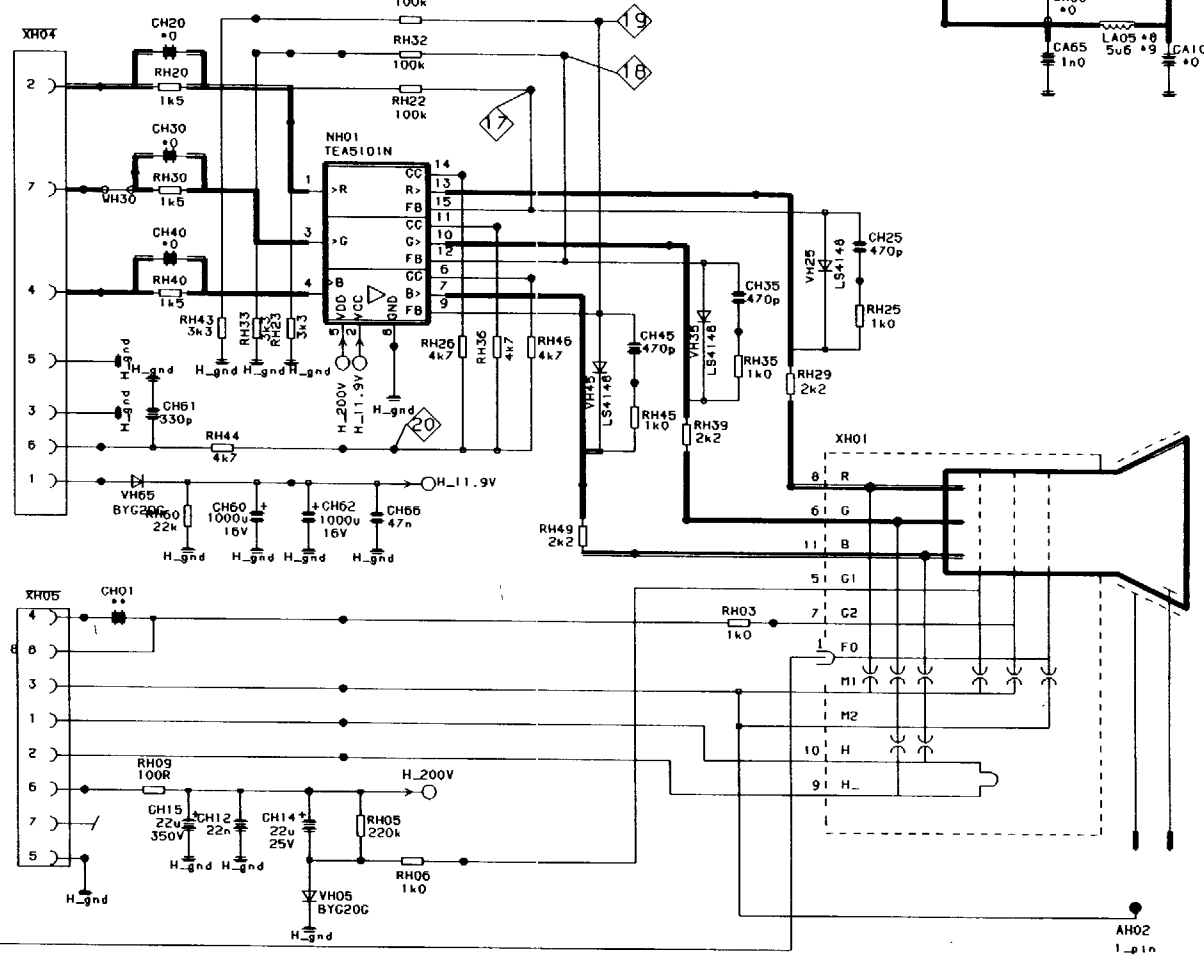
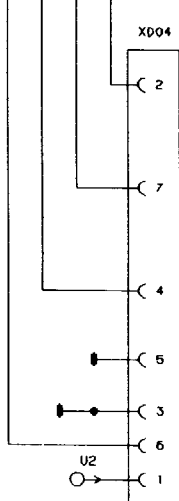

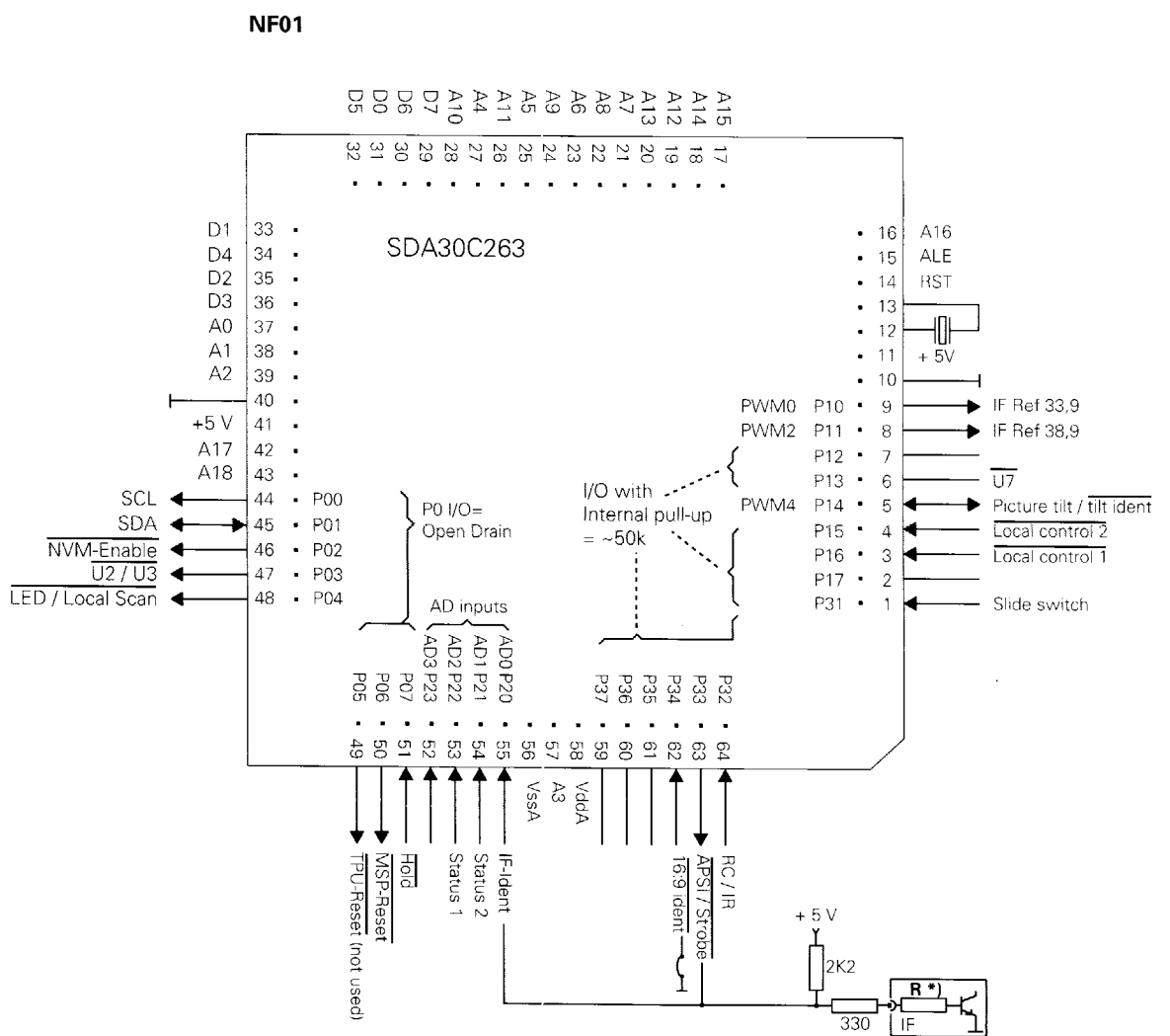
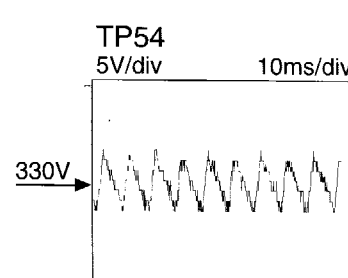
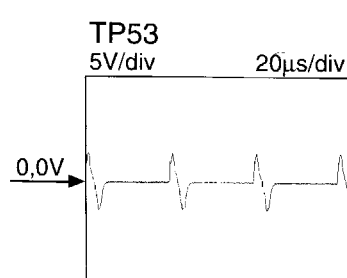
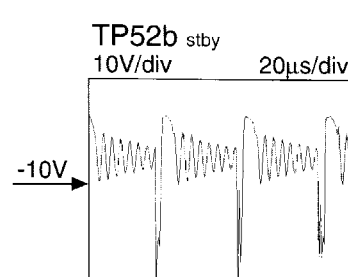
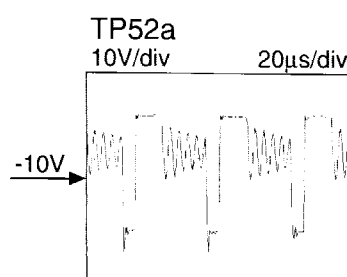
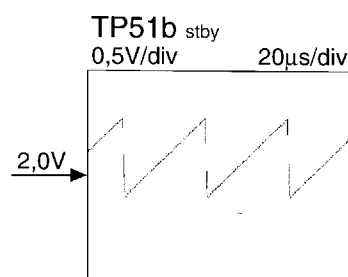
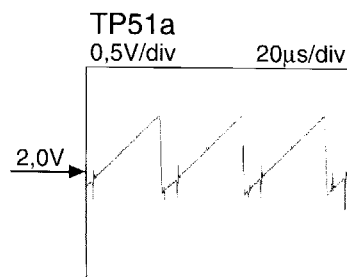
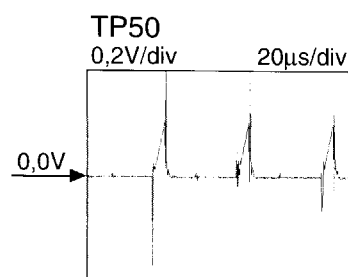
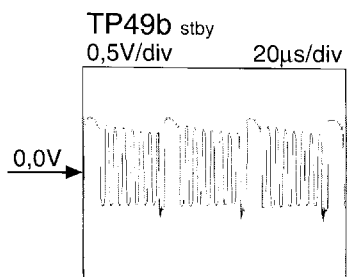
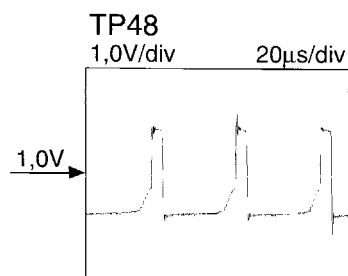
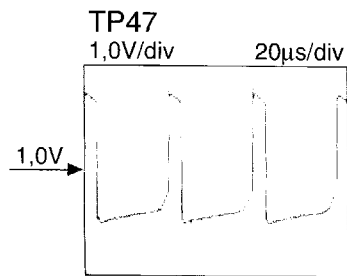
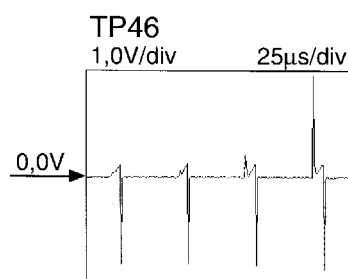
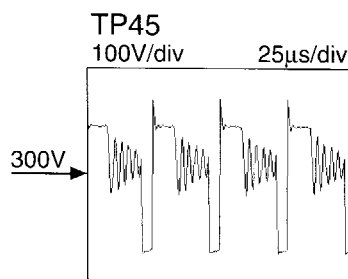
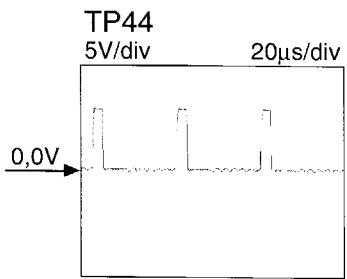
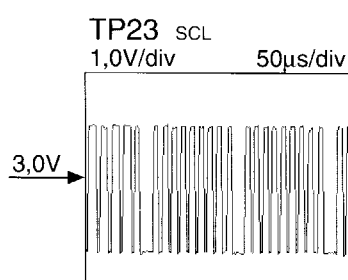
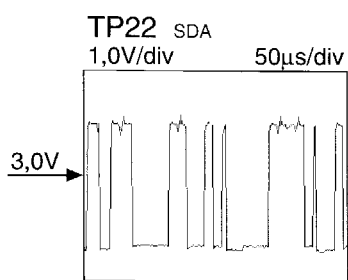
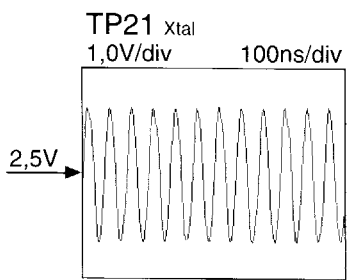

Scart status voltages		
Mode	Scart	µP-pin
4:3	8,5...12V	3,4...5V
16:9	3,5...8V	1,4...3,2V
OFF	0...3V	0...1,2V

AD0 as IF Ident			
Voltages	R *)	IF versions	Frontend mod.
3,9 - 5,0	12k	BG / DK / I / LL'	SR801
3,1 - 3,9	3k9	BG / DK	SR803
2,3 - 3,1	1k5	I	SR802
1,7 - 2,3	680	BG	SR800

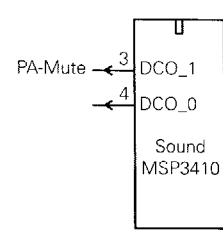

3rd EDITION
**CHASSIS
SP2-SERIE**

